

PATTERN OF SEED LOSSES AND DAMAGE DURING SOYBEAN HARVEST WITH GRAIN COMBINE HARVESTERS*

J. Kowalczyk

Department of Horticultural Machinery, University of Agriculture, Głęboka 28, 20-612 Lublin, Poland

Accepted January 5, 1998

A b s t r a c t. In the paper the results of a five year investigation on harvesting the Progres soybean variety of Polish origin with combine harvesters are presented. This variety is characterized by low podding height of the lowest pods. At the Institute of Agricultural Mechanization of the University of Agriculture in Lublin a design of a tracing cutting assembly was developed whose main objective was to reduce the cutting height of the grain combine harvester. In the following investigation two types of the Z056 Bizon-Super grain combine harvester were compared: one with the standard cutting assembly and the other with the tracing cutting assembly. The results showed that the use of the tracing cutting assembly led to an average reduction of total seed losses from 17.4% to 5.3%. Average losses caused by headers equipped with the tracing cutting assembly were 4.5% compared to the 16.5% typical of the standard design. The losses caused by the threshing assembly averaged 0.84% for both types of the harvester. Of the total losses caused by the headers, seeds from pods attached to the stubble made up the biggest fraction. This fraction amounted to 2.1% for the harvesters equipped with the tracing cutting assembly and 8.3% for the standard harvesters. Mechanical damage of soybean seeds was about 9.9%; of this amount 4.6% was macro-damage and 5.3% microdamage.

K e y w o r d s: soybean, harvest of seeds, losses, damage of seeds

INTRODUCTION

The mechanical harvest of soybean seeds is the most difficult operation in the production technology from the standpoint of technical complexity. New Polish soybean varieties as well as numerous foreign ones are charac-

terized by low podding height of the lowest pods. This is the main cause of seed loss during the harvest of soybean with machines used for harvesting cereals. In those countries where soybean is grown on large areas, it is harvested with grain combine harvesters adapted for low cutting.

Early varieties of soybean, grown in rows spaced closer than 0.5 m are harvested mainly with grain combine harvesters equipped with so-called flexible cutter bars [1]. Late soybean varieties grown in rows spaced farther apart than 0.5 m are harvested with combine harvesters equipped with special row adapters [6].

In Poland investigations on mechanical harvesting of Polish soybean varieties were carried out at the Institute of Plant Breeding and Acclimatization in Radzików [8], the Institute for Building, Mechanization and Electrification of Agriculture in Warsaw [2] and the Institute of Agricultural Mechanization of the University of Agriculture in Lublin [4,5].

The investigations carried out at the Institute of Plant Breeding and Acclimatization in Radzików and at the Institute for Building, Mechanization and Electrification of Agriculture in Warsaw concerned multiphase harvesting of soybean. However, this method of harvesting has not been admitted into practice due to its main drawback which is high loss of seeds.

The investigations carried out at the Institute of Agricultural Mechanization of the University of Agriculture in Lublin concerned the development of a one-phase harvest technique for the harvest of new Polish varieties of soybean implementing the grain combine harvester adapted for low cutting.

OBJECTIVES

The main objective of the investigations was to determine the seed loss and seed damage that occur during harvest of soybean with the Z056 Bizon-Super grain combine harvester equipped with the tracing and with the standard cutting assemblies. The schema of the tracing cutting assembly with the mechanically driven cutterbar is presented in Fig. 1. The assembly makes it possible to go down

with the cutting height as low as 3 cm due to its tracing capability with regard to the irregularities in the field surface.

MATERIALS AND METHOD

The investigations of the Z056 Bizon-Super grain combine harvester equipped with the standard and the tracing cutting assemblies were carried out during harvest of the Progres soybean variety. The investigations were conducted over a five-year period in compliance with the methodology originally developed at the Institute for Building, Mechanization and Electrification of Agriculture in Warsaw [2] which was modified for the current investigations. The harvest was carried out at the peripheral speed of threshing drum in the range of $18.8-23.5 \text{ m s}^{-1}$, the inlet threshing clearance

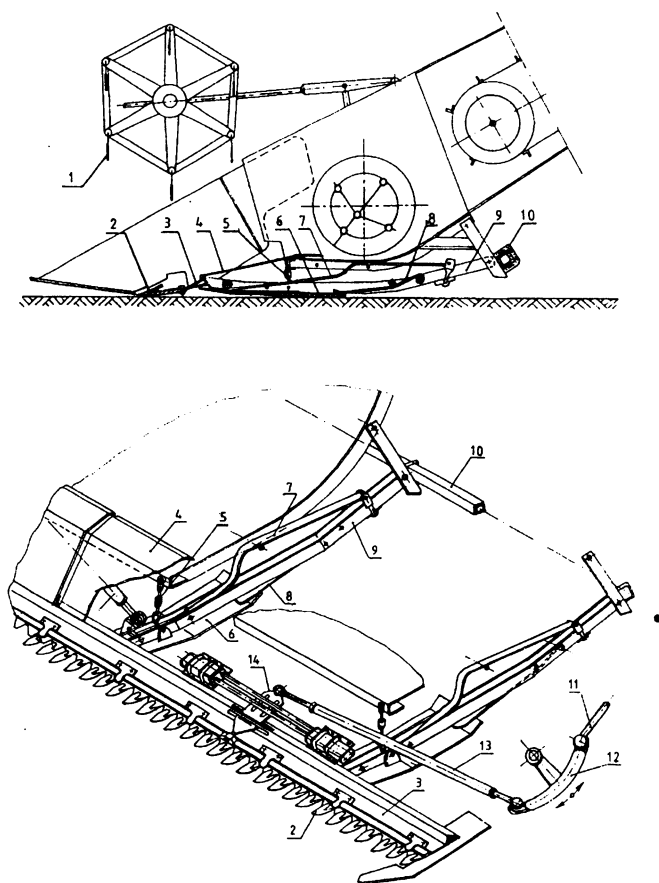

Fig. 1. Schema of the header of the Z056 Bizon-Super grain combine harvester equipped with the tracing cutting assembly: 1-rubber belt, 2-cutter bar finger, 3-finger bar, 4-shield, 5-chain, 6-skid, 7-lightening spring, 8-pressure spring, 9-carrying beam, 10-suspension beam, 11-pitman, 12-angle lever, 13-cross rod, 14-lever with a slide.

of 25-30 mm, the outlet threshing clearance of 10-15 mm, the slot of the upper grain sieve of 10-12 mm and the lower sieve of 8-10 mm and the angular velocity of the fan shaft of 90-96 s⁻¹.

The seed losses caused by the harvester were taken from four randomly-selected plots 50 m long, whose width was equal to the average cutting width of the header. After each plot had been harvested and the straw and gleanings had been gathered, a 1x4 m measuring frame was placed across the plot and four samples were taken from each plot. From inside the frame pods connected to the stubble, loose seeds, loose pods and pods connected to the plants were taken separately. The losses in (kg m⁻²) were calculated by dividing the mass of seeds gathered from inside the frame by the area of the frame. The header losses in (kg ha⁻¹) and (%) were calculated by subtraction of the self-shatter. In order to determine the losses caused by the threshing assembly, the straw and gleanings were put through treatment to isolate seeds. The threshing losses represented seeds from unthreshed pods and loose seeds found in the straw and gleanings. The losses were calculated in (kg ha⁻¹) and (%).

The mechanical damage of soybean seeds was broken up into macro- and microdamage. In order to determine the macrodamage of seeds three samples 0.2 kg each were taken on each plot from the hopper of the harvester. The analysis of samples consisted in separation of macrodamaged seeds on the principle of visual evaluation and in determination of their mass. The results were given as the percent of the whole sample. The microdamage of

seeds was determined according to the dyeing method. From each sample taken out of the hopper, after the macrodamaged seeds had been separated, three test samples of 100 seeds each were taken. These were treated in a dye bath of 0.5% carmine indigo in water. The solution was imbibed into invisible cracks in the seed shells and imparted a blue colour to them. The microdamaged seeds were then separated and their number was determined and calculated in (%).

RESULTS AND DISCUSSION

The results of the investigations are given in Tables 1, 2 and Fig. 2.

The average height of plants of the Progress variety was about 59 cm, the distance from the surface of soil to the receptacle of the lowest pod was 9 cm and the yield was 2.25 t ha⁻¹ (Table 1).

The results presented in Table 2 indicate that the use of the tracing cutting assembly caused a reduction in the total losses from 17.4% to 5.3% on the average.

Header losses of the harvester equipped with the tracing cutting assembly were 4.5% as compared to 16.5% for the standard combine harvester. It follows that the use of the tracing cutting assembly affected a threefold reduction of seed losses during the harvest of soybean. Threshing losses averaged about 0.84%. Seeds in unthreshed pods contributed the most - 90% to this amount. Generally the amount of unthreshed seeds was closely related to their moisture content at the harvest time.

Table 1. Results of soybean-stand characteristic measurements

No.	Specification	Measurement unit	Results of measurements
1.	Soybean variety	-	Progress
2.	Plants per m ²	pcs.	75.0
3.	Plant height	cm	58.7
4.	Canopy height	cm	50.1
5.	Canopy lodging index	%	14.8
6.	Height of the lowest pod setting	cm	9.0
7.	Pods per plant	pcs.	19.0
8.	Pod characteristic:		
	- length	cm	4.0
	- width	cm	0.96
	- thickness	cm	0.57
9.	Seed moisture content	%	17.8
10.	Seed yield at 15% moisture	t ha ⁻¹	2.25

Table 2. Results of field and laboratory investigations on soybean harvest with the combine harvester

Specification	Measurement unit	Z056 Bizon-Super combine-harvester	
		standard cutting assembly	tracing cutting assembly
Ground speed of harvester	m s^{-1}	0.53	0.58
Thresher throughput	kg s^{-1}	1.3	1.4
Stubble height	cm	8.7	6.1
Total seed losses caused by harvester	%	17.4	5.3
-header losses	%	16.5	4.5
-thresher losses	%	0.9	0.8
Seed purity	%	94.5	94.9
Mechanical damage of seeds	%	9.9	9.9
-macrodamage	%	4.6	4.7
-microdamage	%	5.3	5.2
Efficiency of harvester	ha h^{-1}	0.78	0.84

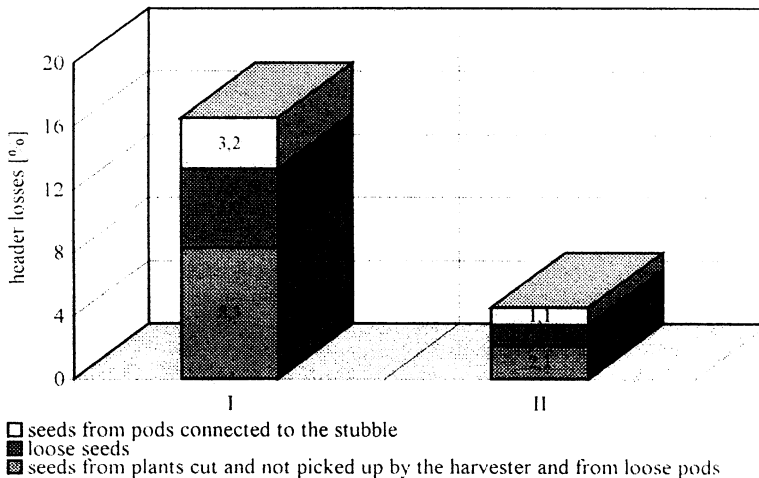

Fig. 2. The structure of soybean seed losses caused by the headers under investigation: I-Z056 Bizon-Super combine harvester header equipped with the standard cutting assembly, II-header of the Z056 Bizon-Super combine harvester equipped with the tracing cutting assembly.

Much the same results concerning losses of seeds during harvest of soybean with grain combine harvesters equipped with flexible cutter bars and row adapters were achieved by Bichel *et al.* [2] and Nave *et al.* [8], Bagaglia *et al.* [1] and Gutbiani [5].

The biggest losses caused by the header were seeds in pods connected to the stubble (Fig. 2). They averaged 2.1% for the tracing cutting assembly and 8.3% for the standard cutting assembly.

Mechanical damage of soybean seeds averaged about 9.9%, 4.6% being macrodamage and 5.3% microdamage. The damage was

closely related to the moisture content of seeds and the settings of the threshing assembly.

CONCLUSION

During the harvest of soybean with a grain combine harvester, quantitative losses of seeds are mainly caused by the header, and their quantity depends before all on the cutting height. Mechanical damage of soybean seeds is developed mainly in the threshing assembly of the harvester and the helical conveyors. Its magnitude depends before all on the peripheral speed of the threshing drum and the size of the threshing clearance.

To sum up the above the tracing cutting assembly can be recommended for the use with a grain combine harvester for harvest of domestic soybean varieties. Soybeans should be harvested at a seed moisture content below 20%, with the peripheral speed threshing drum within the range of 18.8-23.5 m s⁻¹, inlet threshing clearance of 25-30 mm and outlet threshing clearance of 10-15 mm.

REFERENCES

1. **Bagaglia L., Bolli P., Farina G.:** La raccolta della soia in Umbria. *Macch. Motori agr.* 46, 5, 17-20, 1988.
2. **Bichel D.C., Hengen E.J., Mott R.E.:** Designing the new concept header. *Agric. Engng.* 57, 9, 21-23, 1976.
3. **Goć K.:** Methodology of testing grain combine harvesters (in Polish). Institute for Building, Mechanization and Electrification of Agriculture, Warszawa, 1970.
4. **Gulik R., Cieřła Z.:** Two-stage harvest of soybean with the use of the cutter developed at the Institute for Building, Mechanization and Electrification of Agriculture, a rake and a pick-up trailer (in Polish). Institute for Building, Mechanization and Electrification of Agriculture, Warszawa, 1977.
5. **Gutbiani R.:** Le testate per la raccolta della soia. *Macch. Motori agr.* 46, 2, 33-39, 1988.
6. **Kowalczuk J.:** Single-stage soybean seeds harvest with the grain combine harvester (in Polish). *Rocz. Nauk Roln.*, 75-C-3, 35-47, 1983.
7. **Kowalczuk J.:** Problems of the soybean seeds harvest machanization (in Polish). *Zesz. Probl. Post. Nauk Roln.*, 297, 380-388, 1986.
8. **Nave W.R., Hummel J.W., Yoerger R.R.:** Air-jet and row-crop headers for soybeans. *Trans. ASAE* 20, 6, 1037-1041, 1044, 1977.
9. **Woynarowska S.:** The Soybean (in Polish). PWRiL, Warsaw, 1972.